

THIS DRAWING IS UNPUBLISHED. RELEASED FOR PUBLICATION  
 © COPYRIGHT BY TYCO ELECTRONICS CORPORATION. ALL RIGHTS RESERVED.

| LOC | DIST | REVISIONS   |                           |         |        |
|-----|------|-------------|---------------------------|---------|--------|
| P   | LTR  | DESCRIPTION | DATE                      | DWN     | APVD   |
| AF  | 50   | E           | REVISED PER ECR-10-006099 | 07JUL10 | HMR PD |

- CONTINUOUS STRIP ON REELS AT 21.72±0.13 [.855±.005] FEED.
- WIRE SIZE IS [18-14] AWG.
- INSULATION RANGE IS 3.05-4.06 [.120-.160] DIA.

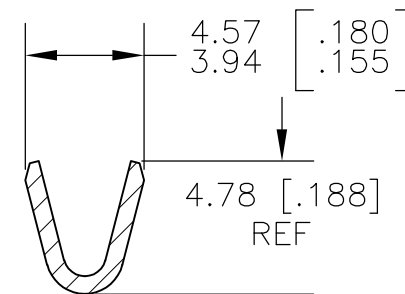
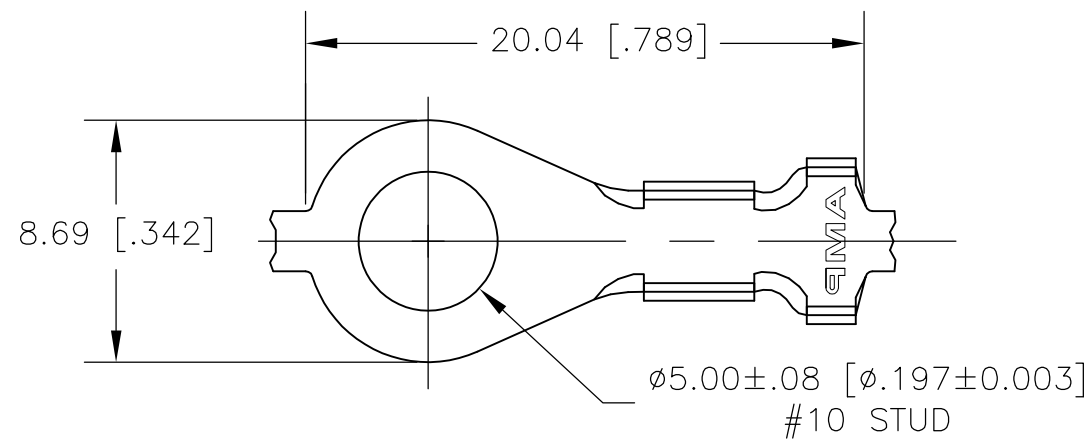

SECTION A-A

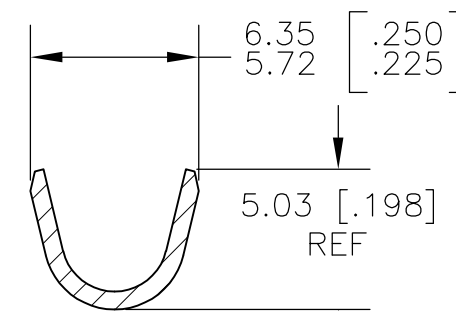
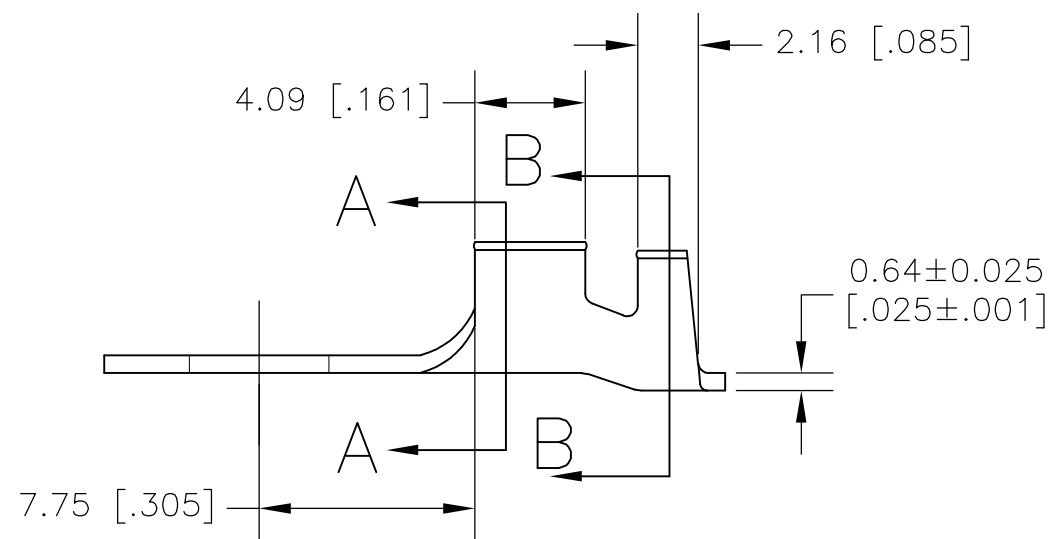

SECTION B-B

|        |          |
|--------|----------|
| TIN    | 60744-2  |
| -      | 60744-1  |
| FINISH | PART NO. |

|  |                     |                             |   |                    |                       |       |               |       |     |       |     |        |     |                   |                    |  |
|--|---------------------|-----------------------------|---|--------------------|-----------------------|-------|---------------|-------|-----|-------|-----|--------|-----|-------------------|--------------------|--|
| THIS DRAWING IS A CONTROLLED DOCUMENT.   |                     | DWN<br>JR RUTH<br>15NOV00   | Tyco Electronics Corporation<br>Harrisburg, PA 17105-3608 |                    |                       |       |               |       |     |       |     |        |     |                   |                    |  |
| DIMENSIONS:<br>mm [INCHES]   |                     | CHK<br>MS FEHER<br>17NOV00  |   |                    |                       |       |               |       |     |       |     |        |     |                   |                    |  |
| TOLERANCES UNLESS OTHERWISE SPECIFIED:   |                     | APVD<br>D DECKER<br>17NOV00 | NAME<br>RING  |                    |                       |       |               |       |     |       |     |        |     |                   |                    |  |
| <table border="0"> <tr><td>0 PLC</td><td>± -</td></tr> <tr><td>1 PLC</td><td>± -</td></tr> <tr><td>2 PLC</td><td>± 0.38 [.015]</td></tr> <tr><td>3 PLC</td><td>± -</td></tr> <tr><td>4 PLC</td><td>± -</td></tr> <tr><td>ANGLES</td><td>± -</td></tr> </table> |                     | 0 PLC                       | ± -   | 1 PLC              | ± -                   | 2 PLC | ± 0.38 [.015] | 3 PLC | ± - | 4 PLC | ± - | ANGLES | ± - | PRODUCT SPEC<br>- | RESTRICTED TO<br>- |  |
| 0 PLC  | ± -                 |                             |   |                    |                       |       |               |       |     |       |     |        |     |                   |                    |  |
| 1 PLC  | ± -                 |                             |   |                    |                       |       |               |       |     |       |     |        |     |                   |                    |  |
| 2 PLC  | ± 0.38 [.015]       |                             |   |                    |                       |       |               |       |     |       |     |        |     |                   |                    |  |
| 3 PLC  | ± -                 |                             |   |                    |                       |       |               |       |     |       |     |        |     |                   |                    |  |
| 4 PLC  | ± -                 |                             |   |                    |                       |       |               |       |     |       |     |        |     |                   |                    |  |
| ANGLES   | ± -                 |                             |   |                    |                       |       |               |       |     |       |     |        |     |                   |                    |  |
| MATERIAL<br>1/2 HD BRASS   | FINISH<br>SEE TABLE | APPLICATION SPEC<br>-       | SIZE<br>A3  | CAGE CODE<br>00779 | DRAWING NO<br>C-60744 |       |               |       |     |       |     |        |     |                   |                    |  |
| CUSTOMER DRAWING   |                     |                             | SCALE<br>4:1  | SHEET<br>1 OF 1    | REV<br>E              |       |               |       |     |       |     |        |     |                   |                    |  |